

MAPA Products

MPH-24-D:24/9 Pedestal Hydrant

July 2011

Installation Instructions – Parts List

Description of the Hydrant:

The MAPA Pedestal Hydrant with Auto-Drain is a hydrant assembly utilizing a full port ball valve with an auto-drain port that is located below freeze line at the base of the Hydrant. An auto-drain type hose vacuum breaker is permanently attached to the discharge outlet located near the top of the pedestal. The assembly is housed within a stainless steel shroud.

The assembly is ideally suited for applications where severe cold weather is of concern. The auto-drain port will discharge the water remaining in the standpipe to an open-site drain that is located below the roof line.

The Stainless Steel Shroud and Base allow the roof contractor to make a positive, weather tight flashing to the Hydrant.

The Under-deck Flange prevents the Hydrant from becoming dislodged from the roof membrane during operation.

The Weather-Guard Domed Handle prevents moisture from entering the assembly when the valve is in the OFF position.



Unpacking the Hydrant:

Parts Included:

- Hydrant Assembly
- Under-deck flange
- Wye-strainer W/ brass nipple
- Assembly Hardware
- Installation Instructions

Assembly Hardware is located in a plastic bag that is attached to the underside of the under-deck flange.

Parts:

- 4 – 1/4" X 1" set screws
- 4 – 1/4" X 1 1/2" hex head bolts
- 1 – 1/4" MIP X Compression Adapter

Verify that all assembly parts are present.

Recommended Installation Procedures:

Support Framing: We strongly recommend that prior to the installation of this roof mounted Pedestal Hydrant that a welded angle frame be installed at the bottom surface of the roof decking. This framing should be of sufficient size to permit the provided under-deck flange to slide freely yet firmly into the frame and rest firmly against its top. The framing should be of sufficient strength to prevent any dislodging of the Hydrant during normal operation. Refer to **Figure 1** of these instructions.

Installation Sequencing:

We recommend that the Hydrant not be installed until the roof decking and all roof insulation is in place. A round hole should be cut in the roof insulation and deck to permit the hydrant to pass from the roof surface through this hole to below with the base resting squarely on the insulation. We do not recommend making final piping connections to the Hydrant until all roof work associated with making the hydrant base watertight to the roof is completed and then not until the under-deck clamp has been installed.

Connections to the Water Source:

We recommend that a wye-strainer and valve be installed on the supply piping serving the hydrant. This valve should be in a convenient and easily accessible location. Because the drain port operates as an auto-drain, a second drain-down valve is not required between this port and the termination point of the discharge piping. The drain-down piping should discharge open-site to a sanitary receptacle such as a mop sink. Local, governing plumbing codes should be followed when installing this hydrant and making piping connections to the building water system. Optimal water pressure at the hydrant supply should be 60 PSI (typical city water pressure), however it will still operate properly at a minimum of 20 PSI.

Installation of the Hydrant: A hole approximately six inches (6") in diameter should be cut in the roof decking. The hole should be centered on an angle frame welded to the roof structure below the decking. Once roof insulation is in place, cut through the insulation and place the Hydrant base squarely onto the roof surface. Square the Hydrant, pointing the nozzle in the desired direction.

Refer to **Figure 2**.

Caution should be taken to assure that the Hydrant is vertically level above the roof. We do not recommend installing the Hydrant within four feet of the edge of the roof or within three feet of other roof top equipment or on any sloping surfaces of the roof.

Installation of the Under-deck Flange:

Once roofing work at the Hydrant has been completed, the under-deck flange should be installed. Slide the under-deck flange from below, over the lower portion of the hydrant's shroud. Snug the flange securely to the deck and angle framing. Using the four (4) 1/4" X 1 1/2" bolts, secure the flange to the angle framing. Care should be taken to insure that the under-deck flange is firm against the bottom of the roof deck while tightening these set screws. See **Figure 3**

Next, using the four (4) 1/4" X 1" set screws, securely fasten the under-deck flange to the stainless tubing.

Refer to **Figure 3** of the Instructions.

Water Supply Test: It is recommended that the water supply be thoroughly tested prior to activating the Hydrant. To avoid damage to the valve ball, stem or seat, the water supply system should also be purged of all foreign materials before the supply valve to the Hydrant is opened.

Winterizing - Severe Weather Drain-down: If the drain-down port on the ball valve of the hydrant discharges in a downward sloping manner and is terminated open-site at a sanitary receptacle then there is no concern that the assembly or stand-pipe will be subject to freezing. **Caution:** To insure positive discharge of the water remaining in the stand-pipe after the valve is closed, any hose or fitting connected to the outlet of the hydrant should be removed.

MAPA PRODUCTS MPH-24D PEDESTAL HYDRANT

Figure 1

Welded AngleFrame Detail
ID Dimension 12-1/2 inches square 
Secure Angle Framing To Support Structure

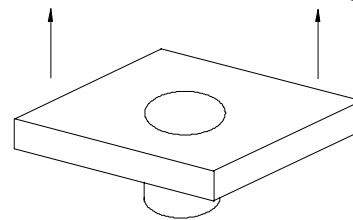
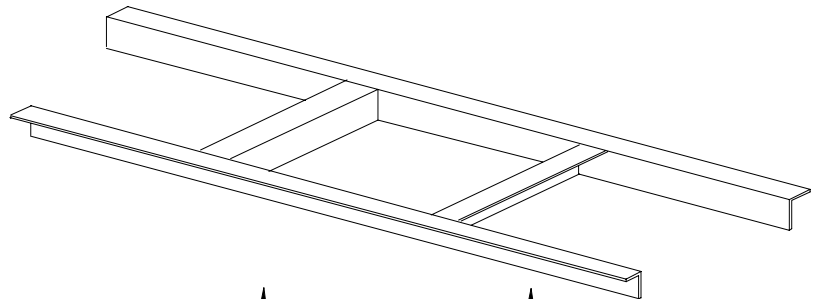

Under-deck flange should freely slide upward into angle frame opening.

Figure 2

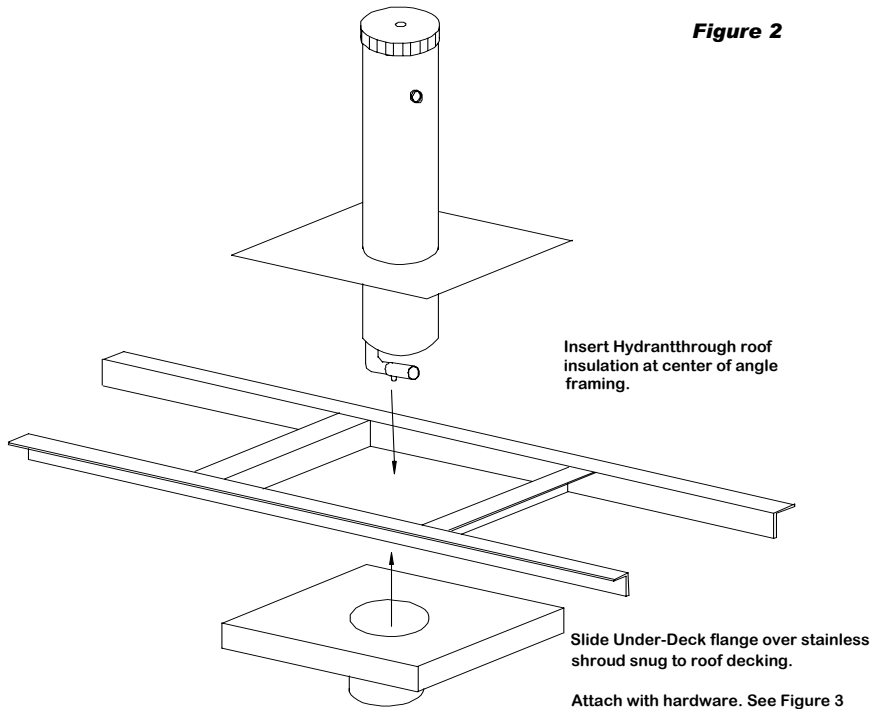

Installation of the Supply and Drain Piping: Make water supply and drain-down connections only after the under-deck flange is securely attached to the Hydrant. Remove the plastic plug from the ball valve inlet. First install the factory provided wye-strainer and then connect appropriate piping connections. Remove and discard the plastic plug from the drain-down port. Install the provided 1/4" compression fitting. Connect copper tubing and discharge to a convenient sanitary receptacle. See **Figure 3**

Where it is determined for the installation that no drain-down piping is necessary, a 1/4" brass plug (not provided) should be installed in the port. Teflon tape should be applied at the threaded connection.

Installation of the supply and drain-down piping should conform to standard plumbing practices and be in accordance with local, governing codes. The drain-down piping should discharge to an open-site plumbing receptacle or other approved device.

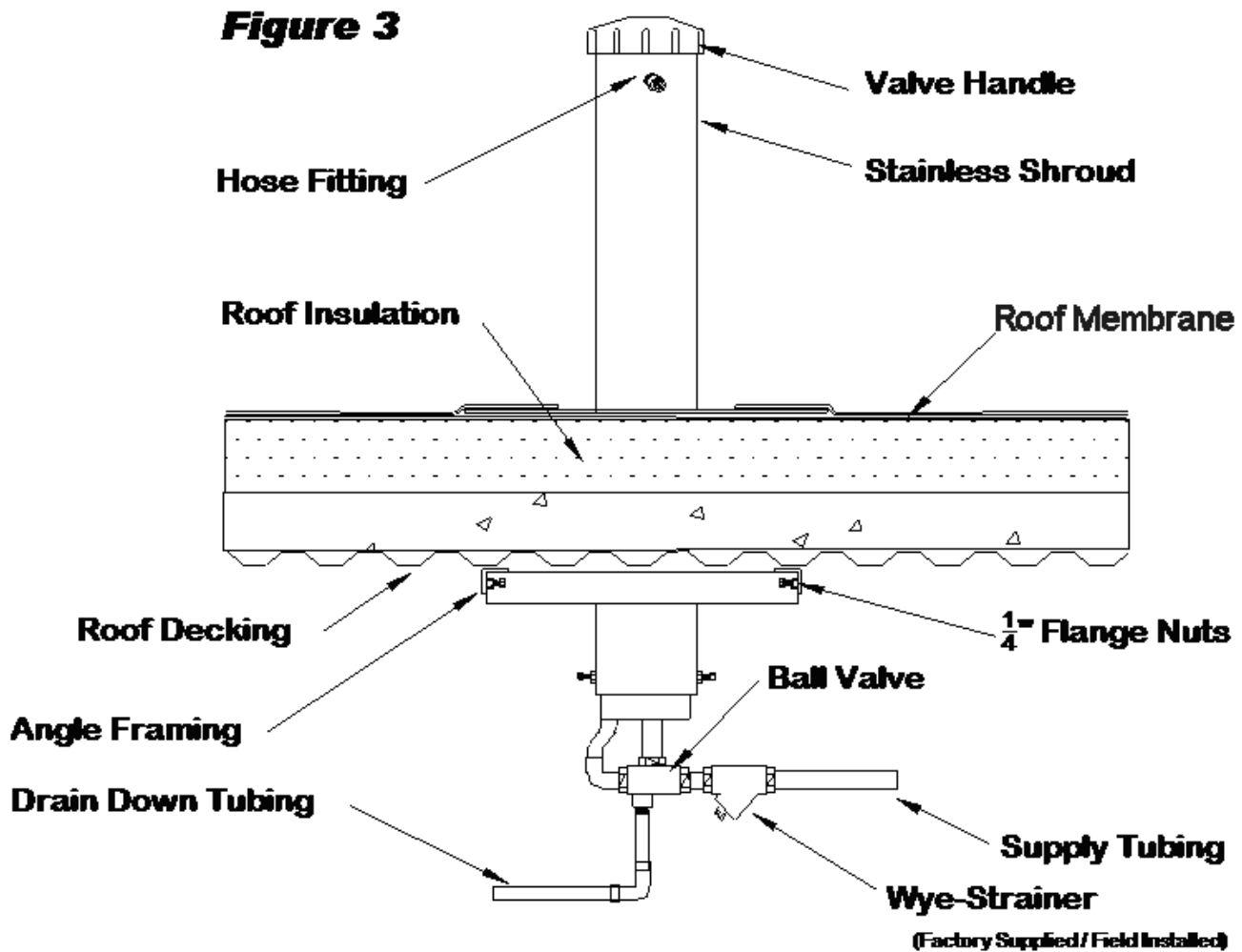

Maintenance:

A periodic test of the Hydrant should be performed. The dome handle should be opened and closed to assure that no foreign material has entered the cavity within the dome. Difficulty in turning the handle is a possible indication of the presence of foreign matter within. To remove this matter, first remove the plastic cap at the top of the handle. Second, loosen and remove the ¼" lock-nut and washers inside the cavity below this cap.

After removal of any foreign material, replace the handle and attachment hardware.

The hydrant should periodically be examined to insure that the working and operating parts function as intended. The hose threads on the vacuum breaker should be free of indentation that may cause a hose to not attach properly to the hydrant. The vacuum breaker should function as intended allowing for air to enter the stand-pipe once the valve is closed while barring fluids from back-flowing into the assembly.

The provided wye-strainer should be installed as shown in Figure 3, and at least annually be cleaned of debris. Contamination in the water supply line may cause the valve to fail. The strainer screen mesh should be removed and flushed and then re-installed prior to continued use of the hydrant.

Repairing the Ball Valve:

The ball valve and assembly is not intended for "in the field" repairs or replacement by those not trained as to the technique of removal and re-assembly of the valve and piping assembly. If it does become necessary to make repairs to this hydrant, contact an authorized factory service technician.

Replacing the Dome Handle:

If the dome handle is broken, replacements are available. Please contact your local MAPA Representative to obtain repair parts.

Limited Warranty:

MAPA will repair or replace any defective parts or workmanship of this product for a period of one year from date of delivery. Damage caused by incorrect installation, alteration or improper usage is not warranted. The failure to install a wye-strainer immediately upstream of the ball valve, and/or the failure to routinely clean the mesh screen in the strainer may cause valve damage and will void the warranty. Recovery rights shall be limited to the total sum of the amounts paid for the product by the purchaser.

DISCLAIMER OF IMPLIED WARRANTY:

THERE ARE NO WARRANTIES THAT EXTEND BEYOND THE DESCRIPTION HEREIN. SELLER DISCLAIMS ANY IMPLIED WARRANTY OF MERCHANTABILITY OF THE GOODS OR OF THE FITNESS OF THE GOODS FOR ANY PURPOSE, AND BUYER AGREES THAT THE GOODS ARE SOLD "AS IS."

Limits of Liability:

MAPA's liability shall be limited to costs of repair or replacement parts. Pedestals are not intended for usage other than those expressly described in this document. MAPA shall not be liable for damage or injury caused by the improper use of the product.