



Downdraft Table with Vented Back Stop

Tables Using Patented DualDraw® Airflow Technology

The DualDraw Downdraft Table with its signature vented back stop is an air filtration solution designed to balance containment with versatility.

This downdraft table incorporates the patented DualDraw airflow design of the perforated surface and vented back stop with a flexible panel filter system configured to the application.

The DualDraw approach to downdraft quality and performance is unique in the marketplace – we guarantee your satisfaction.



BG3072 Front View

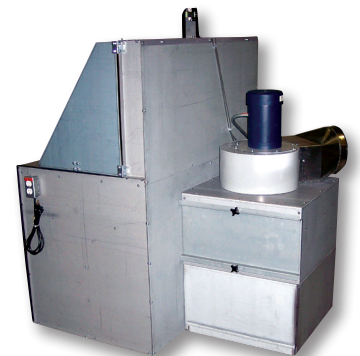

**Rear View with Smoke/Fume
Collection Filter Housing**



**Rear View with Dust
Collection Filter Housing**





WWW.DUALDRAW.COM
800-977-2125

SPECIFICATIONS

Design Name	DualDraw Downdraft Table with Vented Back Stop
Standard Models	BG3036 (30"D X 36"W work surface), BG3048 (30"D X 48"W work surface), BG3060 (30"D X 60"W work surface), BG3072 (30"D X 72"W work surface), BG3096 (30"D X 96"W work surface). Low Flow or High Flow. Filter system designation: D (Dust Collection), F (Smoke/Fume Removal), IS (Internal System), H (HEPA).
General Specifications	
Characteristics	Patented DualDraw design: even distribution of airflow across a perforated surface and vented back stop. Modular fastening system provides design flexibility to meet customer requirements in a cost-effective manner. Self contained solution; outdoor exhausting not necessary.
Filtration Systems	Filtration systems attach to the back side of equipment or are located internally. Choose between dust collection, smoke or fume removal, and HEPA filtration. All filter systems come with cleanout trays and hand-removable access doors for filter maintenance ease.
Dust	Dust filter housings are modular and attach to the back of the unit. Dust filter housing dimensions are 24"D x 24"W x 80"H. Cleanout tray for ease of maintenance.
Smoke/Fume	Smoke/Fume filter housings are modular and attach to the back of the unit. Smoke/Fume filter housing dimensions are 24"D x 24"W x 48"H. Cleanout tray for ease of maintenance.
Internal	Internal filter systems are located inside the table and accessed through a door located on the bottom front. Internal filter systems reduce overall depth by 24" and are a practical solution when space is limited. Cleanout tray for ease of maintenance.
HEPA	HEPA filter systems for dust, smoke, or fumes are available. HEPA systems can also be located internal. Cleanout tray for ease of maintenance.
Available Sizes	Standard lengths are 36", 48", 60", 72", and 96". Standard depth of the work surface is 30". Table footprint extends an additional 24"D to account for the filter housing. Flexible design construction allows customers to cost-effectively specify non-standard sizes.
Work Surface Area	The standard surface area of a DualDraw downdraft table ranges from 4.5ft ² to 20ft ² . The surface of the equipment is a series of 5"W perforated C-channel grates. Each grate has evenly spaced 1/2" x 3/16" perforations that create an equal distribution of downdraft across the surface.
Table Capacity	500 lbs. -1,000 lbs. distributed weight. Reinforced grates and table sides available for heavy-duty use.
Cabinet	12-16 gauge modular body construction.
Finish	Electro Galvanized. Powder coat paint finish available.
Filters	A set of new filters are included with the unit. Discount replacement filter kits are available through the DualDraw website. Depending on the application, the following may be contained in a unit: <ul style="list-style-type: none"> • Standard 24" x 24" x 4" pleated prefilter. 40% efficient to 0.7 microns. MERV 7. • Standard 24" x 24" x 4" pleated final filter. 95% efficient to 0.7 microns. MERV 14. • Standard 24" x 24" x 30" 10-pocket dust bag filter. 85% efficient to 1.0 micron. MERV 13. • Standard 24" x 24" x 2" activated carbon filter for fume removal. 6 lbs. • Optional 24" x 24" x 11.5" HEPA filter. 99.97% efficient to 0.3 microns. MERV 17. • Optional 24" x 24" x 12" activated carbon filter. Heavy-duty. 60 lbs.
Spark Arrestor	Heavy-duty steel spark arrestor to catch residual particulate and reduce fire hazard. Standard for applications that create a fire hazard. Washable.
Dust Pans	Optional removable front dust pan for easy cleanout and maintenance. Cleanout tray in filter housing standard on all designs.
Electrical	Units come pre-wired with manual motor starter. Thermally protected.
Lighting	Optional on table design. 2 bulb fluorescent.
Motor	Single phase 115/220V or three phase 208/230/460V motor depending on customer requirement. Horsepower ranges from 3/4 HP to 6 HP based on table size and application.
Capture Velocity	Ranges from 100 to 400 FPM depending on application and customer requirement.
Air Volume	Low flow and high flow options available. CFM ranges from 1,200 to 5,000 on standard units. 68% through table surface and 32% through vented back.
Sound	Ranges from 70 -78 dB at operator work zone. Optional silencer package.
Magnehelic Gauge	Pressure gauge provides indication of when filters should be checked.
Unit Weight	Varies based on size. Ranges from 700 to 1,500 lbs. uncrated.
Caster wheels	Optional heavy-duty 3.5" caster wheels for ease of movement.
Assembly	None required. Ships complete, FOB Commerce City, CO.
Regulatory	Helps meet OSHA Standard 1910.1000 (air contaminants).

RENDERING - Downdraft Table with Vented Back Stop

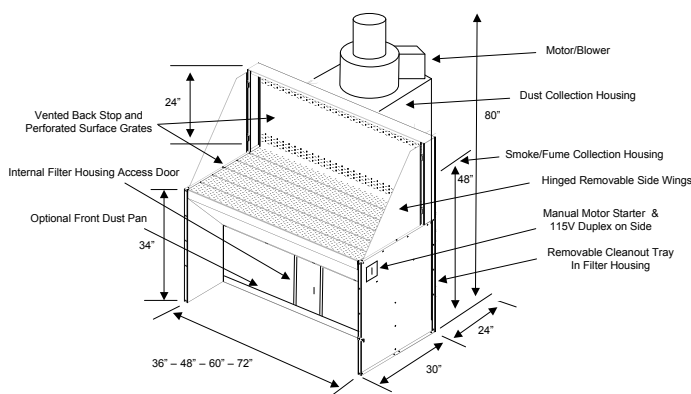

Contract Holder
FSS Contract
GS-25F-0161M

